

TECHNICAL CATALOGUE

ACCESSORIES FOR SOLAR HEATING SYSTEMS



ITAP SpA, founded in Lumezzane (Brescia) in 1972, is currently one of the leading production companies in Italy of valves, fittings and distribution manifolds for plumbing and heating systems. Thanks to fully automated production processes, with 72 tooling machines and 51 assembly lines, we are able to produce 200,000 pieces per day. Our innate pursuit for innovation and observance of technical regulations is supported by the company certification ISO 9001: 2008. The company has always considered its focus on quality as the main tool to obtain significant business results: today ITAP SpA is proud to offer products bearing the approval of numerous international certifying bodies.



ACCESSORIES FOR
SOLAR HEATING
SYSTEMS

SOLAR HEATING

362S

AUTOMATIC AIR VENT VALVE FOR SOLAR HEATING SYSTEMS



SIZE	PRESSURE	CODE	PACKING
3/8" (DN 10)	10bar/145psi	3620038S	10/120
1/2" (DN 15)	10bar/145psi	3620012S	10/120

TECHNICAL SPECIFICATIONS

Body in nickel-plated brass.
 Minimum and maximum working temperatures: -20°C, 180°C.
 Nominal pressure: 10 bar.
 Thread ISO228 (equivalent to DIN EN ISO 228 and BS EN ISO 228).

MATERIALS

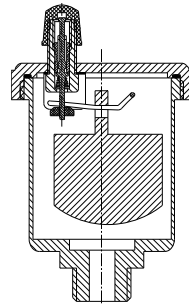

POS.	DESCRIPTION	N.	MATERIAL
-	Body	-	Brass UNI EN 1982
-	Cap	-	Brass UNI EN 1982
-	Float	-	HADSTIF 840 K
-	Cap	-	Brass CW614N
-	O-Ring	-	Red Silicone
-	Mechanism	-	Brass CW614N

OVERALL DIMENSIONS

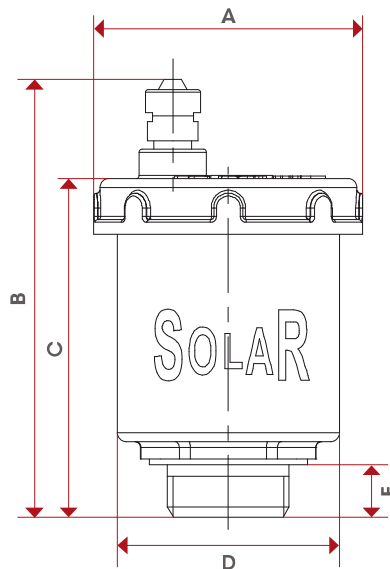

	3/8"	1/2"
A	55	46
B	78,5	75
C	65	58
D	40	38
E	8,5	9
Kg/cm ² bar	10	10
LBS - psi	145	145

CERTIFICATIONS

